

# 2.3.1 KaMOS® leaktest solutions for Kammprofil Gaskets

## The advantages by using KaMOS® RF & FF Gasket:

- The flange is tested for leaks before the process pressure is applied.
- Flanges that would not otherwise be leak or pressure tested (such as blind flanges to isolate spools) can be tested.
- Time of testing is significantly reduced, resulting in less downtime due to leak testing.
- KaMOS® Test Equipment is easy to use.
- Volumes of nitrogen required for testing are minimal, so large quantities of nitrogen and helium will be saved compared to conventional leak testing.
- The KaMOS® test method can also be used for continuous monitoring of seals by equipping the annular space with an indicator of gas pressure.
- The pressurization line can be used to feed in liquid sealant in case of emergency.

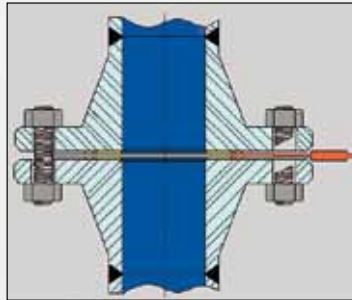

Style FS 150 – 2500 lb – 6,5 mm thk.

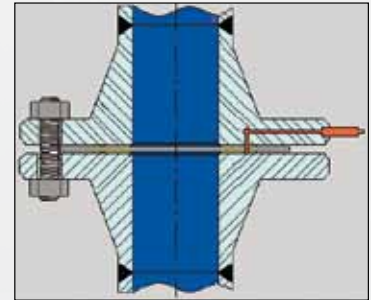

Style FS 150 – 2500 lb – 4,5 mm thk.

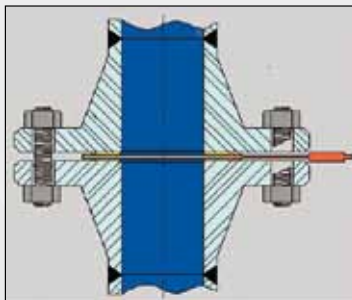

Style FU 150 – 2500 lb – 6,5 mm thk.

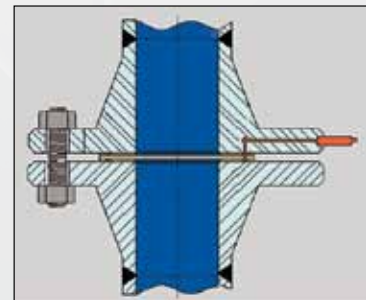

Style FU 150 – 2500 lb – 4,5 mm thk.

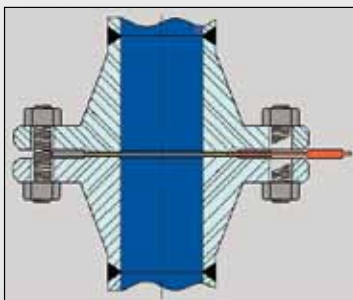

Style RS 150 – 300 lb – 6,5 mm thk.

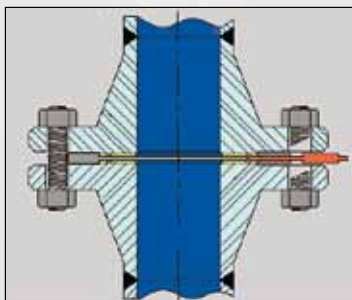

Style RS 400 – 2500 lb – 4,5 mm thk.

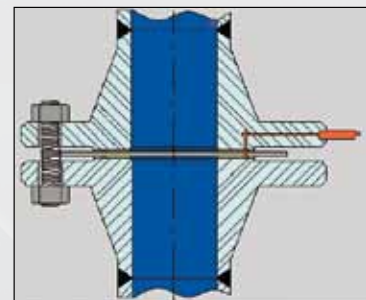

Style RS 150 – 2500 lb – 4,5 mm thk.

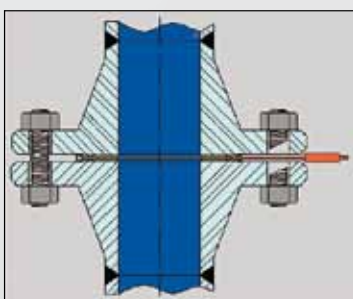

Style RU 150 – 300 lb – 6,5 mm thk.

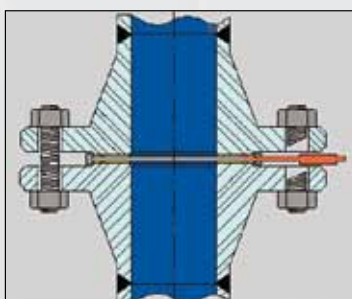

Style RU 400 – 2500 lb – 4,5 mm thk.

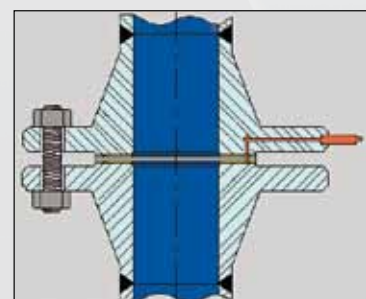

Style RU 150 – 2500 lb – 4,5 mm thk.

RS - Raised face with guide ring

FS - Flat face with guide ring

RU - Raised Face without guide ring

FU - Flat face without guide ring

Patented