

2.2.8 KaMOS® RX Gasket

According to API spec 6A/ISO 10423

Types R and RX Gaskets shall be used on 6B flanges.

Only BX gaskets shall be used with 6BX flanges. RX and BX gaskets is providing a pressure-energized seal but are not interchangeable.

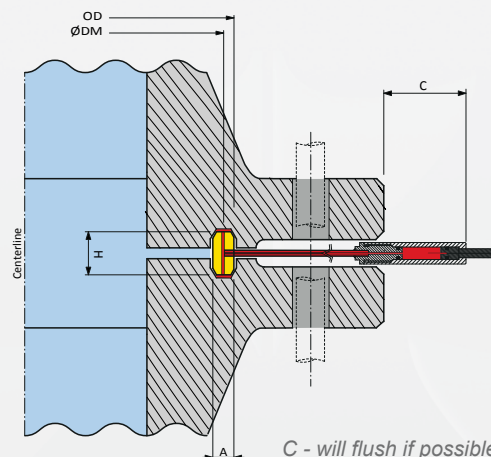

RING NO.	PRESSURE CLASS RATING MPA (PSI)			PITCH DIA. OF RING DM	OUTSIDE DIA. OF RING OD	WIDTH OF RING A	HEIGHT OF RING H	APPROX WEIGHT Kg
	13,8 (2000)	20,7 (3000)	34,5 (5000)					
	NOMINAL PIPE SIZE (INCHES)							
RX20	-	-	-	68,26	76,20	8,73	19,05	0,25
RX20*	-	-	2 1/16	68,26	76,20	8,73	19,05	0,25
RX23	2 1/16	-	-	82,55	93,27	11,91	25,40	0,55
RX24	-	2 1/16	2 1/16	95,25	105,97	11,91	25,40	0,65
RX25*	-	-	3 1/8	101,60	109,54	8,73	19,05	0,35
RX26	2 9/16	-	-	101,60	111,92	11,91	25,40	0,65
RX27	-	2 9/16	2 9/16	107,95	118,27	11,91	25,40	0,65
RX31	3 1/8	3 1/8	-	123,83	134,54	11,91	25,40	0,80
RX35	-	-	3 1/8	136,53	147,24	11,91	25,40	0,90
RX37	4 1/16	4 1/16	-	149,23	159,94	11,91	25,40	1,00
RX39	-	-	4 1/16	161,93	172,64	11,91	25,40	1,00
RX41	-	-	-	180,98	191,69	11,91	25,40	1,20
RX44	-	-	-	193,68	204,39	11,91	25,40	1,30
RX45	7 1/16	7 1/16	-	211,14	211,93	11,91	25,40	1,40
RX46	-	-	7 1/16	211,14	222,25	13,49	28,58	1,70
RX47	-	-	-	228,60	245,27	19,84	41,28	4,00
RX49	9	9	-	269,88	280,59	11,91	25,40	1,80
RX50	-	-	9	269,88	283,37	16,67	31,75	3,00
RX53	11	11	-	323,85	334,57	11,91	25,40	2,20
RX54	-	-	11	323,85	337,34	16,67	31,75	3,50
RX57	13 5/8	13 5/8	-	381,00	391,72	11,91	25,40	2,50
RX63	-	-	-	419,10	441,72	26,99	50,80	12,50
RX65	16 3/4	-	-	469,90	480,62	11,91	25,40	3,10
RX66	-	16 3/4	-	469,90	483,39	16,67	31,75	5,20
RX69	-	-	-	533,40	544,12	11,91	25,40	3,50
RX70	-	-	-	533,40	550,07	19,84	41,28	10,00
RX73	21 1/4	-	-	584,20	596,11	13,49	31,75	5,50
RX74	-	20 3/4	-	584,20	600,87	19,84	41,28	10,30
RX82	-	-	-	57,15	67,87	11,91	25,40	0,40
RX84	-	-	-	63,50	74,22	11,91	25,40	0,45
RX85	-	-	-	79,38	90,09	13,49	25,40	0,55
RX86	-	-	-	90,49	103,58	15,08	28,58	0,85
RX87	-	-	-	100,01	113,11	15,08	28,58	0,95
RX88	-	-	-	123,83	139,30	17,46	31,75	1,50
RX89	-	-	-	114,30	129,78	18,26	31,75	1,40
RX90	-	-	-	155,58	174,63	19,84	44,45	3,20
RX91	-	-	-	260,35	286,94	30,16	45,24	8,00
RX99	-	-	-	234,95	234,95	11,91	25,40	1,55
RX201*	-	-	1 3/8	46,04	46,04	5,74	11,30	0,06
RX205*	-	-	1 13/16	57,15	62,31	5,56	11,10	0,08
RX210*	-	-	2 9/16	88,90	97,63	9,53	19,05	0,40
RX215	-	-	4 1/16	130,18	140,89	11,91	25,40	0,80
RX215*	-	-	4 1/16 x 4 1/4	130,18	140,89	11,91	25,40	0,80

* Denotes API Ring Type Joints for segmented flanges for dual completions to API Standard 6A

Patented

Specifications and images are subject to change without notice. Not responsible for typographical errors. © 2011-1 KaMOS® PRODUCTS - Karmasund Maritime Offshore Supply AS. All rights reserved.